

MLR116MOD_DESIGNER

90° Flush Mount Wrap Around Modular Grab Rail RH in Designer Black

Dimensions: 1100mm x 1025mm x 600mm

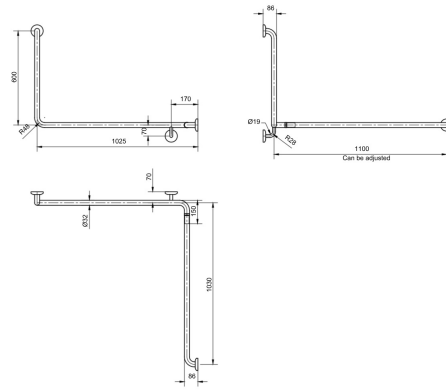

SPECIFICATION

Material	#304 Grade Stainless Steel - 32mmØ
Finish	Designer Black
Mounting	Concealed Fix - 78mmØ Mount

NOTES

- For Metlam Australia Care and Maintenance Guidelines, Installation Instructions, Product Specifications, and Warranty Details, please refer to the Product User Guide Tab.

 This unit is accessible compliant when installed in accordance with AS1428.1 guidelines.

 For more in depth information, visit the product online:
https://metlam.com.au/category/grab-rails/MLR116MOD_DESIGNER